

# Industrial Air Operated Winches



Manufactured for the harshest environments in construction, mining and offshore applications with proven durability, performance and reliability !

These winches are fitted, "as standard" with unique safety features such as dual brakes - incorporating an Automatic Failsafe Brake!

## INDUSTRIAL AIR WINCHES

- **Quick "Dog" clutch** allows the easy payout of wire rope. For safety, as standard this is disengaged, however it can be activated upon customer request prior to or after delivery, the clutch mechanism is found to be useful for certain applications.
- The **spool valve** controls the speed and it is the common design for all models. The positive control spool valve gives the operator excellent control over the speed on both winding in and out of the wire rope.
- **Dual brake system:** Having the dual brake system provides maximum safety! One automatic FAILSAFE brake is activated instantly even if the air supply is lost and operator holds activation lever "open" - providing the ultimate in safety! A secondary manual band brake is located on the winch as well.
- **Simple and Robust design:** The design of these winches makes them very durable especially in dirty and humid environments. We have units that are over 20 years old still in service and parts readily available!
- **Cast iron housing** is robust and durable - this allows the unit to be suitable for a wide range of applications, including underground mining and other hazardous areas.
- **Easy servicing:** The simple design means easy servicing, especially on site. The rotary vane motor can withstand certain contaminants better than other designs. The access to the motor is very quick and easy and can be achieved by simply removing one end cap without having to dismantle other components - saving you time!
- **Rated to lifting capacity at FULL DRUM**, unlike some other winches that are rated to mid drum, you know what your limits are up front - at full drum.

### Specifications: TAW AIR WINCH Series 500 - 2,000kg Lifting Capacity

Model	Lifting Capacity At top layer (kg)	Air Pressure (MPA)	Rope Speed (m/min)	Air Cons (m <sup>3</sup> min)	Weight (kg)	Standard Wire Rope Dimension See next page for more options (mm x m)	Hose Size (mm)	Mounting Bolts (mm)
TAW-500	500	0.4	15.0	2.7	75	8 X 100	19.0	M12 X 4
		0.5	17.8	3.1				
		0.6	20.0	3.4				
TAW-1000	1,000	0.4	7.8	3.2	90	10 X 114	19.0	M12 X 6
		0.5	10	3.6				
		0.6	11.5	3.9				
TAW-1500	1,500	0.4	5.9	3.2	90	12 X 60	19.0	M12 X 6
		0.5	7.3	3.7				
		0.6	8.5	4.1				
TAW-2000	2,000	0.4	4.3	4.1	130	16 X 63	19.0	M12 X 6
		0.5	5.2	4.5				
		0.6	5.7	4.9				

TAW-500



TAW-1000



TAW-1500



TAW-2000



## INDUSTRIAL AIR WINCHES

TAW Series winch wire rope storage capacities (m)

Wire Rope Diameter (mm)	TAW-500	TAW-1000	TAW-1500	TAW-2000
4	444	793	793	1302
5	266	515	515	816
6	187	323	323	538
8	100	165	165	300
10		114	114	184
12		60	60	106
13				98
14				71
16				63
<b>Rope Hole Diameter (mm)</b>	9.5	13.5	13.5	17.5

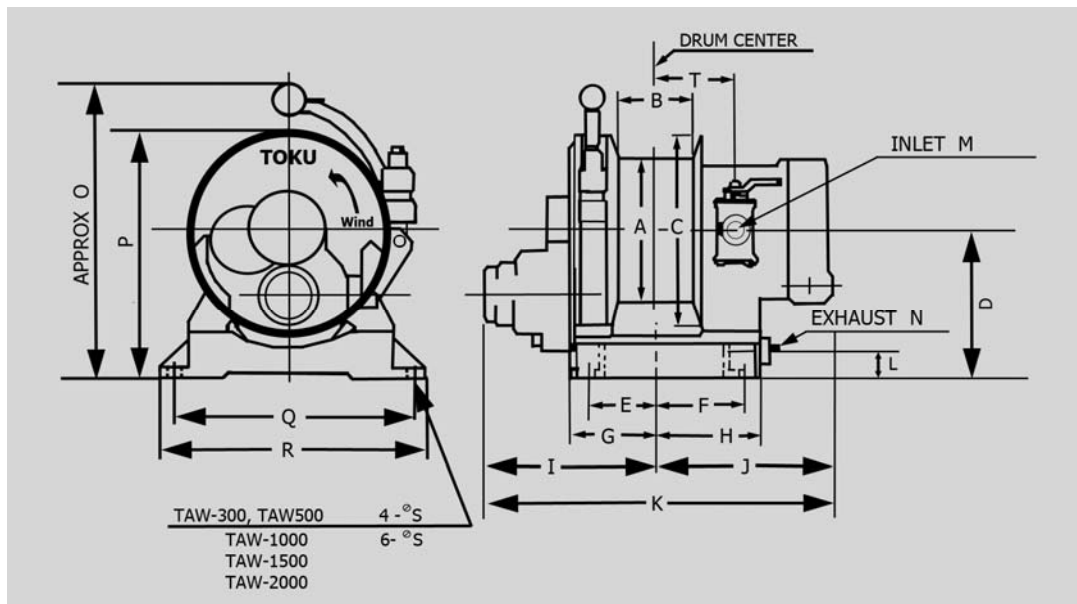

Model	A	B	C	D	E	F	G	H	I	J	K	L	M	N	O	P	Q	R	S	T
TAW-500	180	150	308	225	200	160	220	180	255	220	475	58	Male 3/4PT	Female 1-1/4PT	447	380	310	350	14	134
TAW-1000	200	243	340	225	254	208	270	226	316	366	581	58	Male 3/4PT	Female 1-1/4PT	448	397	310	350	14	172
TAW-1500	200	243	340	225	254	208	270	226	316	266	581	58	Male 3/4PT	Female 1-1/4PT	448	397	310	350	14	172
TAW-2000	300	243	460	286	249	207	269	226	307	274	581	41	Male 3/4PT	Female 1-1/4PT	583	516	420	460	14	172

Note: Dimensions are in millimetres. Dimensions and specifications subject to change without notice.